

SECTION A-A

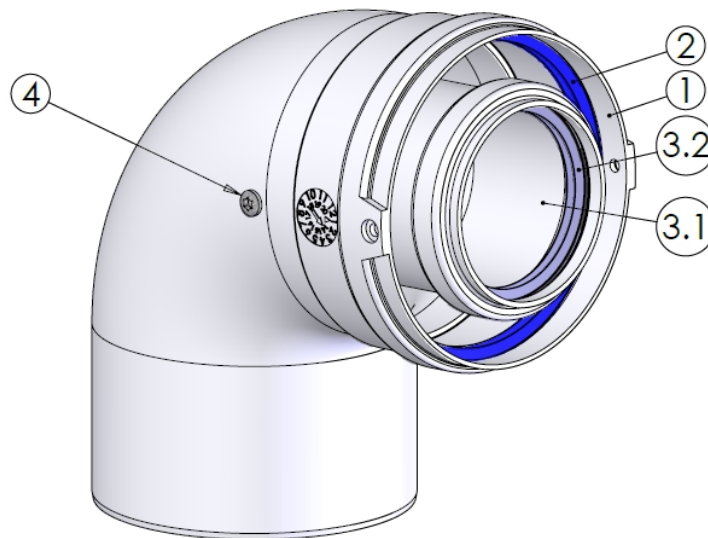

4	2	Screw 4.2 x 13	Galvanized
3.2	1	Seal ø60	EPDM Flue gas
3.1	1	Bend ø60 87° with cams	PPs
3	1	Bend ø60 87° with cams	-
2	1	Seal VMQ Air ø100	VMQ Air
1	1	Bend ø100 87°	EN-AC-46000
Pos.	QTY.	Description	Material

Hekon art. : CD60/100-090