

SECTION A-A Unit of measure: mm

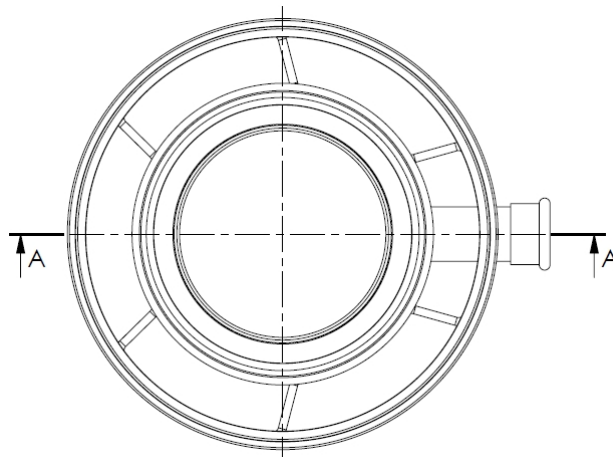

4	1	Spring	AISI 301
3	1	Seal VMQ Air ø150	VMQ Air
2	1	Condensation drain ø150	EN-AW-1050A
1.3	1	Cap, Flue gas, Black	EPDM
1.2	1	Seal EPDM Flue gas ø100	EPDM Flue gas
1.1	1	Condensation drain ø100	-
1	1	Condensation drain ø100	-
Pos.	QTY.	Description	Material

Hekon art. : CD100/150CND