

SECTION A-A

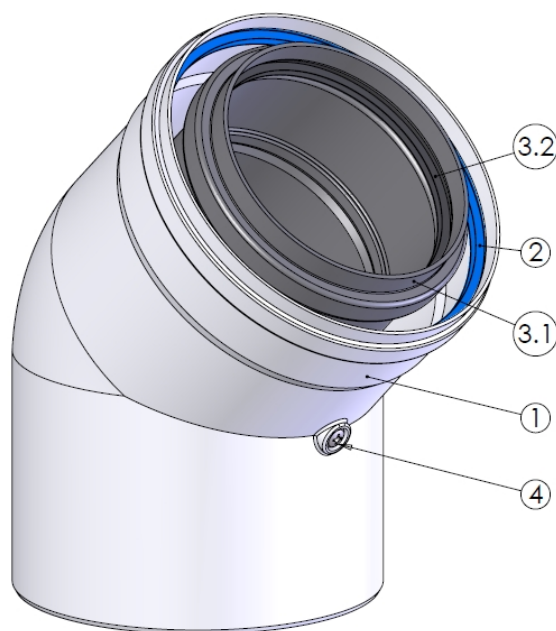
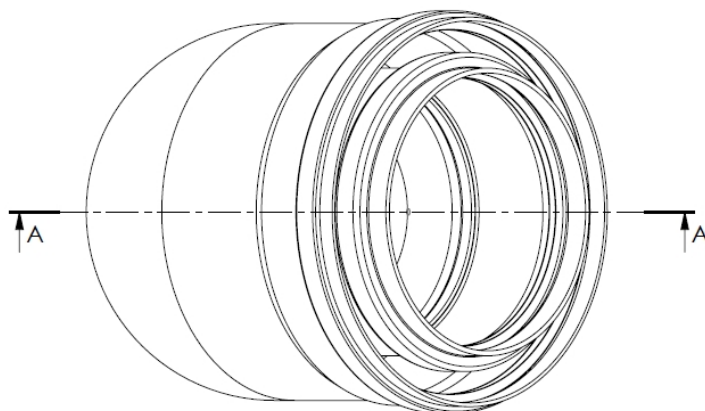

4	1	Screw M5x25	ELVZ
3.2	1	Seal $\varnothing 110$	EPDM Flue gas
3.1	1	Welded bend $\varnothing 110$ 45°	PPs
3	1	Bend $\varnothing 110$ 45°	-
2	1	Seal VMQ Air $\varnothing 150$	VMQ Air
1	1	Bend $\varnothing 150$ 45°	EN-AC-46000
Pos.	QTY.	Description	Material

Hekon art. : CD110/150-45