

Unit of measure: mm

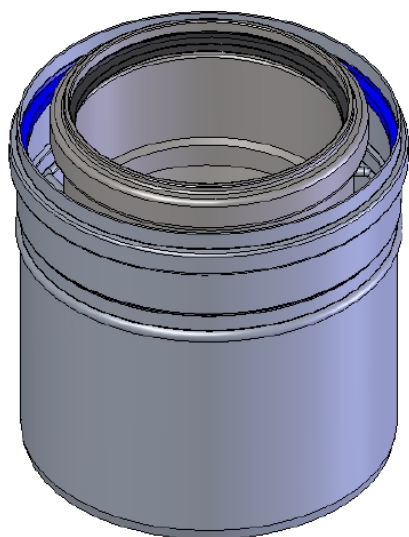

|      |      |   |             |
|------|------|---|-------------|
| 5    | 1    | Seal $\varnothing 150$  | Silicone    |
| 4    | 1    | Seal  | EPDM        |
| 3    | 1    | Spring  | 1,4310      |
| 2    | 1    | Flue pipe Expansion $\varnothing 100$ - $\varnothing 110$ L=160 | PPs         |
| 1    | 1    | Air pipe $\varnothing 150$ L=150                                | EN-AW-1050A |
| Pos. | Qty. | Description   | Material    |

Hekon art. : CD110/150-VG