

SECTION A-A

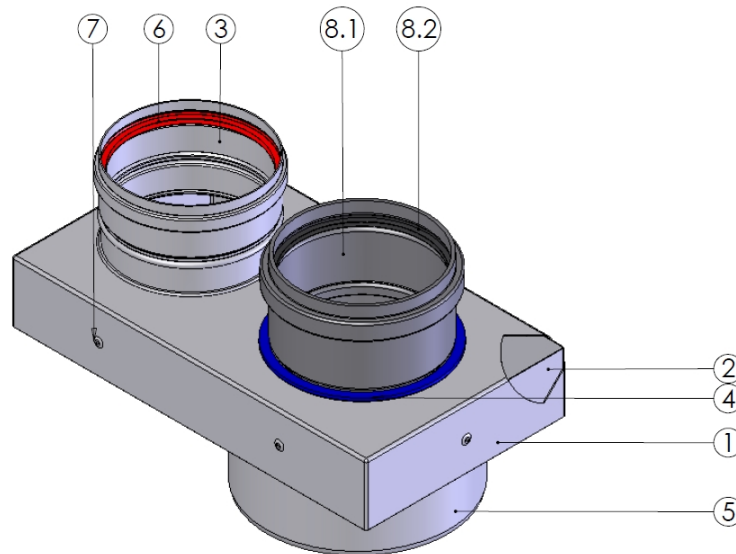

8.2	1	Seal	EPDM	L0295	891198
8.1	1	Flue Pipe	PPs	-	-
8	1	Flue Pipe D110	-	L0287	891299
7	6	Rivet	EN-AW-1050A	-	860001
6	1	Seal ø110	Silicone	07336	700360
5	1	Air pipe	EN-AW-1050A	-	-
4	1	Distance ring ø110	Silicone	08176	890194
3	1	Air inlet pipe	EN-AW-1050A	-	-
2	1	Innerbucket	EN-AW-1050A	-	-
1	1	Outerbucket	EN-AW-1050A	-	-
Pos.	QTY.	Description	Material	Drawing	Part nr

Hekon art. : CD110/160ONT